

Multi-Stage Centrifugal Pump

MODEL

HSC

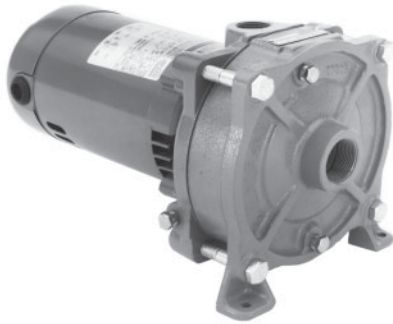

APPLICATIONS

Specifically designed for the following uses:

- Water circulation
- Booster service
- Liquid transfer
- Spraying systems
- Jockey pump service
- General purpose pumping

SPECIFICATIONS

Pump

- Capacities: to 50 GPM.
- Pressures: to 94 PSI (217 feet).
- Pipe connections: 1 1/4" suction 1" discharge.
- Temperatures: to 180°F (82°C) max.
- Maximum working pressure: 125 PSI.
- Rotation: right hand, ie; clockwise when viewed from motor end.

Motor

- NEMA standard 3/4 – 1 1/2 HP, 115/230 V; 2 HP, 230 V, 60 Hz.
- Single phase (standard).
- Three phase available – see price book for order numbers.
- 3500 RPM.
- Built-in overload with automatic reset.
- Capacitor type.
- Stainless steel shaft.

FEATURES

■ Multi-stage Design:

Provides steady, quiet and vibration-free operation for years of trouble-free service.

■ **Impellers:** 20% glass-filled thermoplastic precision molded for high efficiencies.

■ **Compact Design:** Close-coupled, space saving design provides easy installation. Flexible coupling and bedplate not required.

■ **Mounting:** Can be mounted in vertical or horizontal position.

■ Stainless Steel Pump Shaft:

Hex design provides positive drive for impellers and eliminates clearance adjustments.

■ Corrosion Resistant:

Stainless steel wear rings and coverplates. Electro-coated paint process applied inside and out and then baked on.

■ **O-rings:** Throughout for positive sealing.

■ **Easy to Service:** Can be taken apart for service by removing four bolts.

■ **Motor:** Close coupled design. Ball bearings carry all radial/axial thrust loads. Designed for continuous operation. All ratings are within working limits of the motor.

Single Phase Models

HP	Order No.	Stages
3/4	HSC07	2
1	HSC10	2
1 1/2	HSC15	2
2	HSC20	3

COMPONENTS

Item No.	Description
1	Mechanical seal
2	Impellers
3	Intermediate stage
4	Casing
5	Stainless steel hex shaft
6	Stainless steel wear rings
7	Stainless steel cover plates
8	O-ring seals
9	Impeller bolt and washer

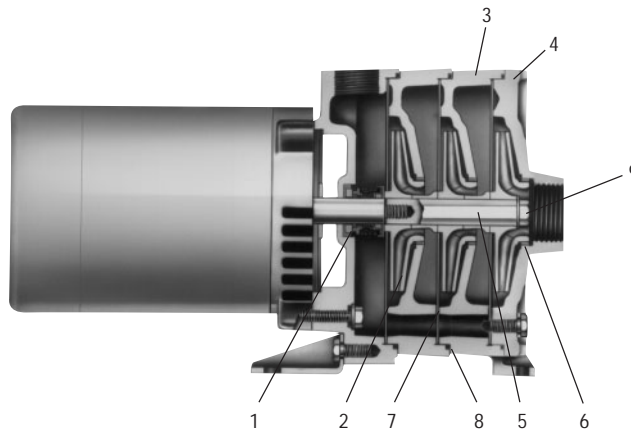

Goulds Pumps is ISO 9001 Registered.

DIMENSIONS AND WEIGHTS

Model	HP	Length	Width	Height	Wt. (lbs.)
HSC07	¾	15	8	9	53
HSC10	1	16	8	9	58
HSC15	1½	17	8	9	72
HSC20	2	19	8	9	75

(All dimensions are in inches and weight in lbs. Do not use for construction purposes.)

PERFORMANCE CURVE

