



Close-Coupled Centrifugal Pumps

MODEL

3642

APPLICATIONS

Specifically designed for the following uses:

- Water circulation
- Booster service
- Liquid transfer
- Spraying systems
- Jockey pump service
- General purpose pumping

SPECIFICATIONS

Pump

- Capacities: to 110 GPM
- Heads: to 118 feet
- Pipe connections:

Model	Suction	Discharge
1 x 1¼ - 5	1¼" NPT	1" NPT
1¼ x 1½ - 5	1½" NPT	1¼" NPT

- Maximum working pressure: 125 PSI
- Temperature: standard seal, 212°F (100°C) maximum or 250°F (121°C) with optional high temperature seal.
- Rotation: right hand i.e.; clockwise when viewed from motor end.

Motor

- NEMA standard
- Open drip proof, TEFC, or (explosion proof three phase only) enclosures.
- 60 Hz, 3500 RPM
- Stainless steel shaft
- Single phase: ½-2 HP ODP or TEFC. Built-in overload with automatic reset.
- Three phase:
 - ½-2 HP: ODP, 208-230/460 V
 - ½-2 HP: TEFC, 208-230/460 V
 - ½-2 HP: expl. proof, 230/460 V
- Overload protection must be provided in starter unit. Starter and heaters (3) must be ordered separately.

FEATURES

■ Compact Design:

Close coupled, space saving design provides easy installation. Flexible couplings and bedplates not required.

■ **Mounting:** Can be mounted in vertical or horizontal position.

■ **Construction:** Available in bronze fitted (BF), all iron (AI), or all bronze (AB). Bronze fitted means bronze impeller.

■ **Impeller:** Enclosed design for high efficiencies. Threaded directly on motor shaft. Stainless steel locknut on three phase models requires no clearance adjustments. Balanced for smooth operation.

■ **Casing:** Volute type, cast iron or brass construction. Back pullout design. Discharge can be rotated in eight positions. Vertical discharge standard. Tapped openings provided for priming, venting and draining.

■ **Mechanical Seal:** Standard carbon/ceramic faces, BUNA elastomers, 300 series stainless steel components. Option seals available.

■ **Motor:** Close-coupled design. Ball bearings carry all radial/axial thrust loads. Designed for continuous operation. All ratings are within working limits of the motor.

Goulds Pumps is ISO 9001 Registered.

Goulds Pumps and the ITT Engineered Blocks symbol are registered trademarks and tradenames of ITT Industries.

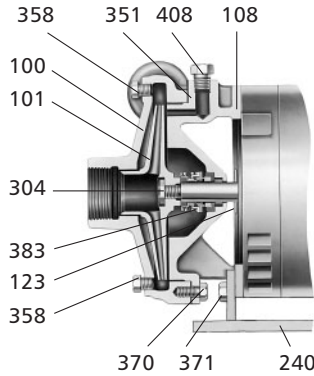

COMPONENTS

Item No.	Description	Material Code					
		Bronze Fitted	All Iron	All Bronze			
100	Casing	1001	1001	1101			
101	Impeller	1101	1001	1101			
108	Adapter	1001	1001	1101			
123	Water deflector	Rubber or Micarta®					
240	Motor Support	Steel					
	Rubber Channel	Rubber					
304	Impeller nut*	Stainless steel					
351	Gasket-casing	Composite					
358	Pipe plug 1/4" vent and drain	Brass	Steel	Brass			
370	Hex head cap screw adapter to case	Zinc-Plated Steel					
371	Hex head cap screw adapter to motor	Zinc-Plated Steel					
408	Prime plug – priming 1/4" NPT	Brass	Steel	Brass			
383	Mechanical Seal						
Order Suffix	10K10	Std.	Service General	Rotary	Stationary	Elastomers	Metal Parts
N	10K6		Heavy Duty	Carbon	Ceramic	BUNA	300 Series SS
O	10K18	Opt.	Hi Temp.		Ni-Resist		
V	10K55		Chem. Duty		Ceramic	Viton	

* Impeller nut furnished on three phase units only.

MATERIALS OF CONSTRUCTION

Material Code	Engineering Standard
1001	Cast iron ASTM A48 CL 20
1101	Bronze ASTM B584, C87500 Lead-Free

MOTOR FRAME

Motor Frame	Single Phase		Three Phase	
	ODP	TEFC	ODP	TEFC/EXPL
48	1/3	—	—	—
56	1/2 – 2	1/2 – 2	1/3 – 2	1/2 – 2

DIMENSIONS AND WEIGHTS

Pump	A	B	D	E	F	H	L	O	P	W	X	Y	Z	CP	Motor Frame	Wt. (lbs.)	
1x1 1/4-5	6 3/4	5 7/8	4 1/8	2 15/16	5	1 3/32	3 3/8	7	7/16	7/16	4	4 1/8	2 1/4	3 1/16	13 1/2	48	55
								15 1/2							56	67	
1 1/2x1 1/2-5							3 3/8	7 7/8			4	2 1/4	2 15/16	15 3/4	56	68	

(All dimensions are in inches and weights in lbs. Do not use for construction purposes.)

