

Pump Performance

- Air Inlet Pressure Range 30 - 90 PSI (2 - 6.1 bar)
- Fluid Pressure Range 1,800 PSI (122.4 bar)
- Max. Rec'd Cycles Per Minute . 60
- Displacement Per Cycle 40.4 in³ (662 cm³)
- Cycles Per Gallon (Liter) 5.7 (1.5)
- Flow @ 60 Cycles / Minute 10.5 GPM (39.6 lpm)
- Noise Level @ 60 Psi 82 db(A) w/muffler

Pump Specifications

- Lower Pump Material Carbon Steel (Nickel Plated)
- Plunger Material Carbon Steel (Chrome Plated)
- Cylinder Material Carbon Steel (Nickel Plated)
- Air Motor 66651-B
- Motor Repair Kit 637110
- Motor Diameter 10"
- Stroke 6"
- Air Inlet 3/4" NPT(F)
- Exhaust Port 1-1/4" NPT(F)
- Chop Check Pump Model 66236-XXE-B
- Lower Pump Repair Kit 637128-XX4-B
- Material Inlet Bolted Flange
- Material Outlet 1-1/2" NPT(F)
- Weight 144 lbs. (65.4 kgs.)

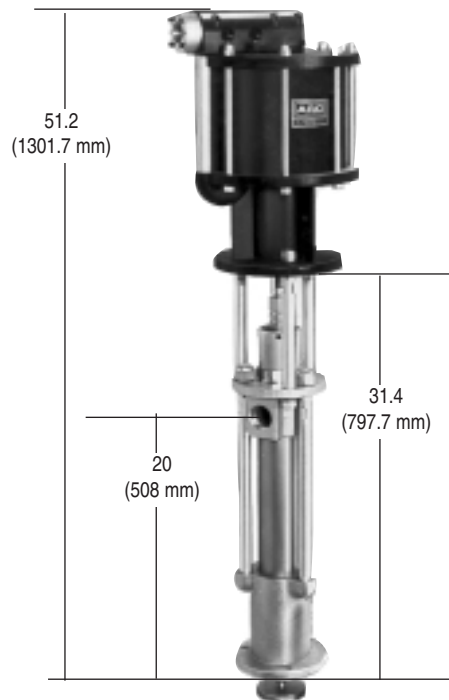

650875-XXE-C

Ordering

6 5 0 8 7 5 -XXE - C

Packings / Springs

- C4 : UHMW-PE (Upper & Lower), Multiple Wave Spring
- F4 : UHMW-PE/Leather Staggered (Upper), UHMW-PE (Lower), Multiple Wave Spring
- J3 : Polyurethane (Upper), UHMW-PE (Lower), No Spring
- P4 : UHMW-PE/Teflon Staggered (Upper), UHMW-PE (Lower), Multiple Wave Spring
- R4 : Teflon/UHMW-PE Staggered (Upper), Teflon (Lower) Multiple Wave Spring

Accessories

- Air F/R/L: 28353
- Airline Oil: 62274
- Air Motor Muffler: 66718
- Wet Sol: 66333-B
- Floor Mount: 65139
- Rams: Page 14

