

Pump Performance

- Air Inlet Pressure Range 30 - 120 PSI (2 - 8.3 bar)
- Fluid Pressure Range 390 - 1560 PSI (26.5 - 106.1 bar)
- Max. Rec'd Cycles Per Minute . 60
- Displacement Per Cycle 40.4 in³ (662 cm³)
- Cycles Per Gallon (Liter) 5.7 (1.5)
- Flow @ 60 Cycles / Minute 10.5 GPM (39.6 lpm)
- Noise Level @ 60 Psi 80 db(A) w/muffler

Pump Specifications

- Lower Pump Material Carbon Steel (Nickel Plated)
- Plunger Material Carbon Steel (Chrome Plated)
- Cylinder Material Carbon Steel (Nickel Plated)
- Air Motor 66523-B
- Motor Repair Kit 66614
- Motor Diameter 8"
- Stroke 6"
- Air Inlet 3/4" NPT(F)
- Exhaust Port 1-1/4" NPT(F)
- Chop Check Pump Model 66236-XXE-B
- Lower Pump Repair Kit 637128-XX4-B
- Material Inlet Flange Mount
- Material Outlet 1-1/2" NPT(F)
- Weight 125.5 lbs. (57 kgs.)

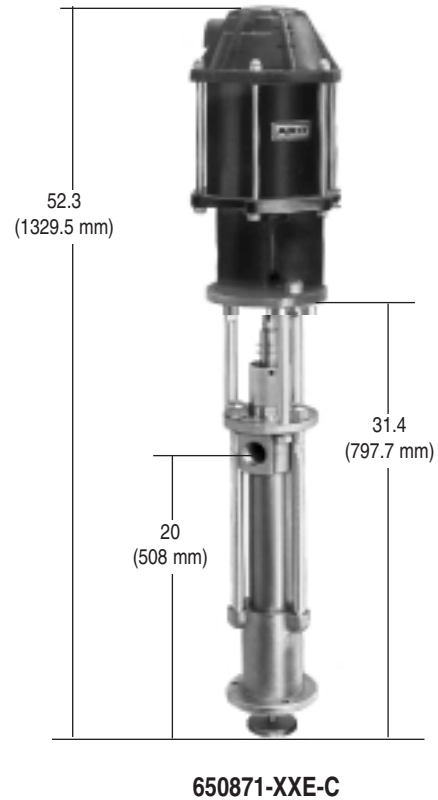

Ordering

6 5 0 8 7 1 - X X E - C

Packings / Springs

- 34** : Glass-Filled Teflon (Upper & Lower), Multiple Wave Spring
- C4** : UHMW-PE (Upper & Lower), Multiple Wave Spring
- F4** : UHMW-PE/Leather Staggered (Upper), UHMW-PE (Lower), Multiple Wave Spring
- J3** : Polyurethane (Upper), UHMW-PE (Lower),
No Spring
- J8** : Polyurethane (Upper), UHMW-PE (Lower), Multiple Wave Spring
- P4** : UHMW-PE/Teflon Staggered (Upper), UHMW-PE (Lower), Multiple Wave Spring
- R4** : Teflon/UHMW-PE Staggered (Upper), Teflon (Lower)
Multiple Wave Spring

Accessories

- Air F/R/L:** 28353
- Airline Oil:** 62274
- Air Motor Muffler:** 92460
- Wet Sol:** 66333-B
- Floor Mount:** 65139
- Ram:** Page 14

