

Pump Performance

- Air Inlet Pressure Range 30 - 120 PSI (2 - 8.3 bar)
- Fluid Pressure Range 1380 - 6900 PSI (93.8 - 469.3 bar)
- Max. Rec'd Cycles Per Minute . 60
- Displacement Per Cycle 6.9 in³ (113 cm³)
- Cycles Per Gallon (Liter) 33.4 (8.8)
- Flow @ 60 Cycles / Minute 1.8 GPM (6.4 lpm)
- Noise Level @ 60 Psi 83 db(A) w/muffler

Pump Specifications

- Lower Pump Material Carbon Steel
- Plunger Material 17.4 Stainless Steel (Chrome Plated)
- Cylinder Material. Carbon Steel (Nickel Plated)
- Air Motor. 65665-B
- Motor Repair Kit 61355
- Motor Diameter 6"
- Stroke 6"
- Air Inlet 1/2" NPT(F)
- Exhaust Port. 1-1/4" NPT(F)
- Chop Check Pump Model. 66266-X43-B
- Lower Pump Repair Kit 637074-X43-B
- Material Inlet Bolted Flange
- Material Outlet 1" NPT(F)
- Weight. 67 lbs. (30.4 kgs.)

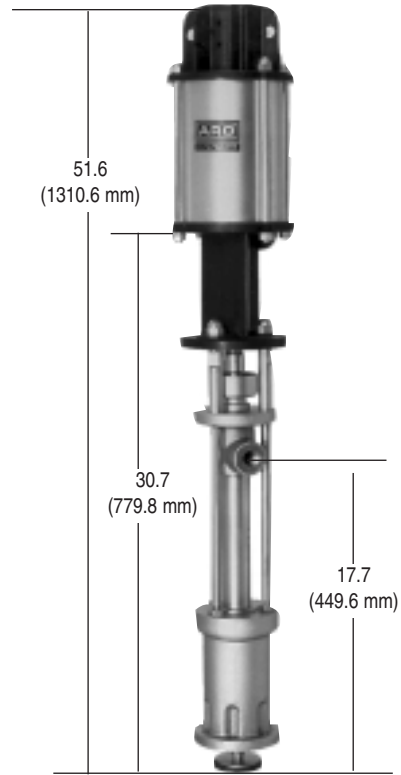

650692-X43-B

Ordering

6 5 0 6 9 2 - X 4 3 - B

Packings

- 3 : Glass-Filled Teflon (Upper & Lower)
- C : UHMW-PE (Upper & Lower)
- G : UHMW-PE/Leather Staggered
- P : UHMW-PE/Teflon Staggered (Upper), UHMW-PE (Lower)
- R : Teflon/UHMW-PE Staggered (Upper), Teflon (Lower)

Accessories

- Air F/R/L: C28241-810
- Airline Oil: 62274
- Air Motor Muffler: 91790
- Wet Sol: 66333-B
- Floor Mount: 65138
- Rams: Page 14

