

Pump Performance

- Air Inlet Pressure Range 30 - 120 PSI (2 - 8.3 bar)
- Fluid Pressure Range 690 - 3450 PSI (46.9 - 234.6 bar)
- Max. Rec'd Cycles Per Minute . 60
- Displacement Per Cycle 12.6 in³ (206.4 cm³)
- Cycles Per Gallon (Liter) 18.3 (4.8)
- Flow @ 60 Cycles / Minute 3.3 GPM (12.4 lpm)
- Noise Level @ 60 Psi 83 db(A) w/muffler

Pump Specifications

- Lower Pump Material Carbon Steel (Nickel Plated)
- Plunger Material 17.4 Stainless Steel (Hard Chrome Plated)
- Cylinder Material Carbon Steel (Nickel Plated)
- Air Motor 65665-B
- Motor Repair Kit 61355
- Motor Diameter 6"
- Stroke 6"
- Air Inlet 1/2" NPT(F)
- Exhaust Port 1-1/4" NPT(F)
- Chop Check Pump Model. 66243-X43-B
- Lower Pump Repair Kit 637071-X43-B
- Material Inlet Bolted Flange
- Material Outlet 1" NPT(F)
- Weight 67 lbs. (30.4 kgs.)

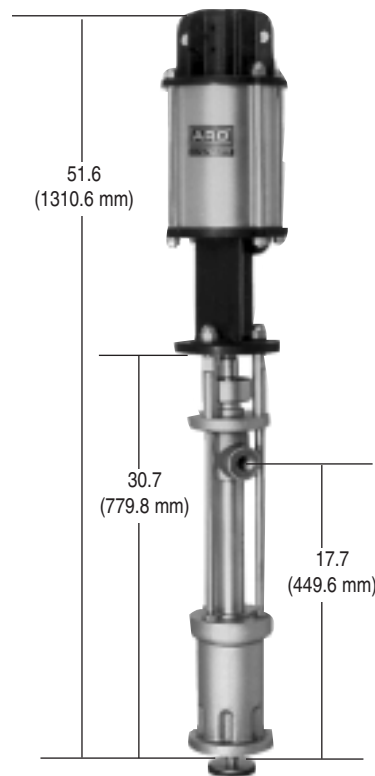

650691-X43-B

Ordering

6 5 0 6 9 1 - X 4 3 - B

- Packings _____
- 3 : Glass-Filled Teflon (Upper & Lower)
 - C : UHMW-PE (Upper & Lower)
 - G : UHMW-PE/Leather Staggered (Upper & Lower)
 - P : UHMW-PE/Teflon Staggered (Upper), UHMW-PE (Lower)
 - R : Teflon/UHMW-PE Staggered (Upper), Teflon (Lower)

Accessories

- Air F/R/L: C28241-810
- Airline Oil: 62274
- Air Motor Muffler: 91790
- Wet Sol: 66333-B
- Floor Mount: 65138
- Rams: Page 14

