

Pump Performance

Air Inlet Pressure Range 30 - 120 PSI (2 - 8.3 bar)
 Fluid Pressure Range 1800 - 6000 PSI (124 - 408 bar)
 Max. Rec'd Cycles Per Minute . 60
 Displacement Per Cycle 5.5 in³ (90.1 cm³)
 Cycles Per Gallon (Liter) 41.9 (11.0)
 Flow @ 60 Cycles / Minute 1.3 GPM (4.9 lpm)
 Noise Level @ 60 Psi 84.8 db(A)

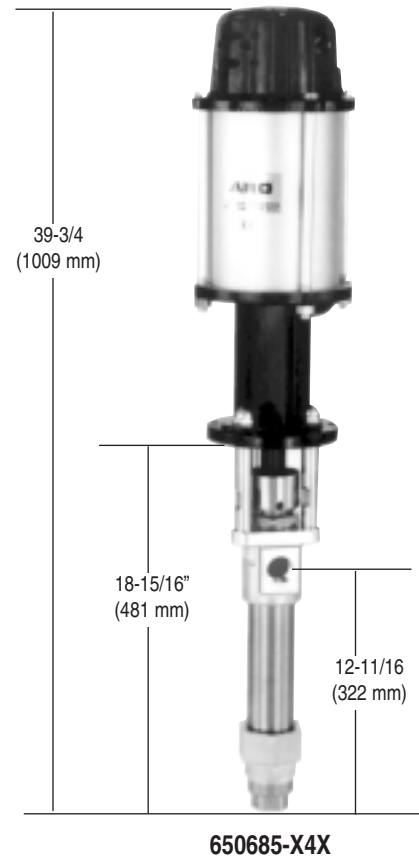

Pump Specifications

Lower Pump Material 316 Stainless Steel
 Plunger Material See "Plunger Options" Below
 Cylinder Material See "Plunger Options" Below
 Air Motor 65665-B
 Motor Repair Kit 61355
 Motor Diameter 6"
 Stroke 6"
 Air Inlet 1/2" NPT(F)
 Two-Ball Pump Model 66302-X4X
 Lower Pump Repair Kit 637307-X43
 Material Inlet 1" NPT(F) 2" NPT(M)
 Material Outlet 1" NPT(F)
 Weight 46.2 lbs. (21 kgs.)

Ordering

6 5 0 6 8 5 -X 4 X
 Packings _____ Plungers _____

- | | |
|---|-----------------------------------|
| 3 : Teflon | 3 : 17-4 S. S. Hard Chrome Plated |
| C : UHMW-PE | B : 17-4 S.S. "Ultra" Coated |
| G : UHMW-PE/Leather Staggered | |
| P : UHMW-PE/Teflon Staggered (Upper), UHMW-PE (Lower) | |
| R : Teflon/UHMW-PE Staggered (Upper), Teflon (Lower) | |

Accessories

- | | |
|-------------------------|------------|
| Air F/R/L: | C28241-810 |
| Airline Oil: | 62274 |
| Air Motor Muffler: | 91790 |
| Wet Sol: | 66333-B |
| Wall Mounts: | 66100 |
| Floor/Follower Adapter: | 67136 |

