

Pump Performance

- Air Inlet Pressure Range 30 - 120 PSI (2 - 8.3 bar)
- Fluid Pressure Range 690 - 3450 PSI (46.9 - 234.6 bar)
- Max. Rec'd Cycles Per Minute . 60
- Displacement Per Cycle 14.5 in³ (237.6 cm³)
- Cycles Per Gallon (Liter) 15.9 (4.2)
- Flow @ 60 Cycles / Minute 3.7 GPM (13.9 lpm)
- Noise Level @ 60 Psi 84.8 db(A)

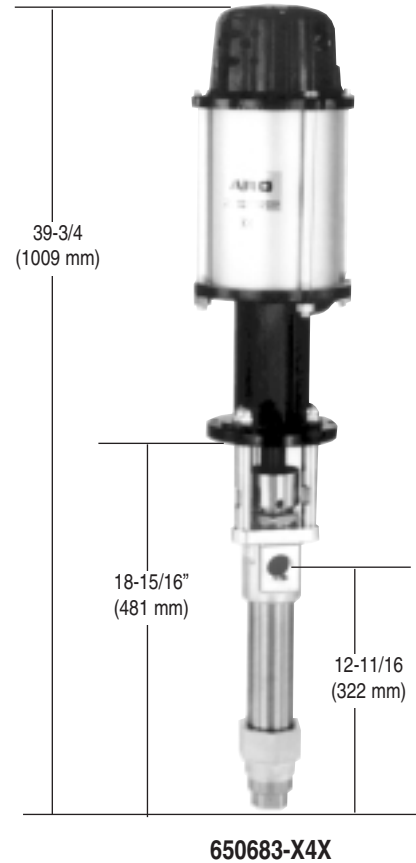

Pump Specifications

- Lower Pump Material 316 Stainless Steel
- Plunger Material See "Plunger Option" Below
- Cylinder Material See "Plunger Option" Below
- Air Motor 65665-B
- Motor Repair Kit 61355
- Motor Diameter 6"
- Stroke 6"
- Air Inlet 1/2" NPTF
- Exhaust Port 1-1/4" NPTF
- Two-Ball Pump Model 66300-X4X
- Lower Pump Repair Kit 637305-X43
- Material Inlet 1" NPT(F) 2" NPT(M)
- Material Outlet 1" NPTF
- Weight 46.2 lbs. (21 kgs.)

Ordering

- 6 5 0 6 8 3 -X 4 X**
- | | |
|--|--|
| Packings | Plungers |
| 3 : Teflon | 3 : 17-4 S. S. Hard Chrome Plated |
| C : UHMW-PE | B : 17-4 S.S. "Ultra" Coated |
| G : UHMW-PE/Leather Staggered | |
| P : UHMW-PE/Teflon Staggered (Upper), UHMW-PE (Lower) | |
| R : Teflon/UHMW-PE Staggered (Upper), Teflon (Lower) | |

Accessories

- Air F/R/L: C28241-810
- Airline Oil: 62274
- Air Motor Muffler: 91790
- Wet Sol: 66333-B
- Wall Mount: 66100
- Floor/Follower Adapter: 67136

