

# Pump Performance

- Air Inlet Pressure Range . . . . . 30 - 120 PSI (2 - 8.3 bar)
- Fluid Pressure Range . . . . . 690 - 3450 PSI (46.9 - 234.6 bar)
- Max. Rec'd Cycles Per Minute . 60
- Displacement Per Cycle . . . . . 6.9 in<sup>3</sup> (113 cm<sup>3</sup>)
- Cycles Per Gallon . . . . . 33 (8.8)
- Flow @ 60 Cycles / Minute . . . . 1.8 GPM (6.8 lpm)
- Noise Level @ 60 Psi . . . . . 80 db(A)

# Pump Specifications

- Lower Pump Material . . . . . Carbon Steel (Nickel Plated)
- Plunger Material . . . . . 17.4 Stainless (Hard Chrome Plated)
- Cylinder Material . . . . . Carbon Steel (Nickel Plated)
- Air Motor . . . . . 65465-B
- Motor Repair Kit . . . . . 61268
- Motor Diameter . . . . . 4-1/4"
- Stroke . . . . . 6"
- Air Inlet . . . . . 1/2" NPT(F)
- Exhaust Port . . . . . 1-1/4" NPT(F)
- Chop Check Pump Model . . . . . 66266-X43-B
- Lower Pump Repair Kit . . . . . 637074-X43-B
- Material Inlet . . . . . Bolted Flange
- Material Outlet . . . . . 1" NPT(F)
- Weight . . . . . 63.7 lbs. (28.9 kgs.)

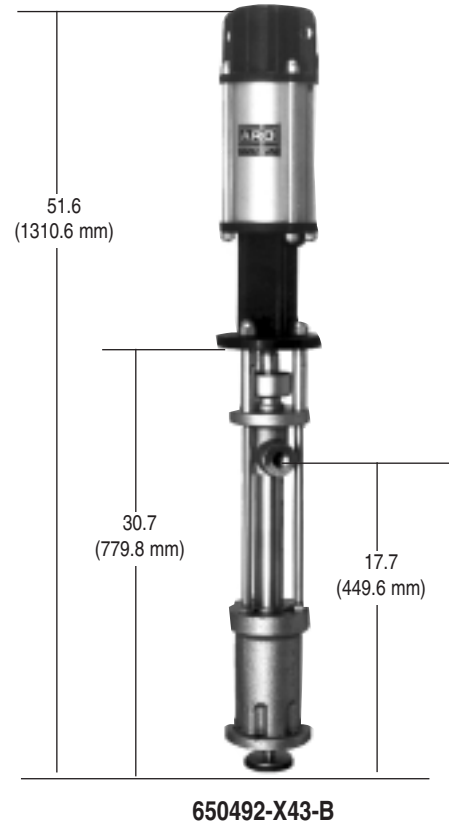

# Ordering

6 5 0 4 9 2 - X 4 3 - B

## Packings

- 3 : Glass-Filled Teflon (Upper & Lower)
- C : UHMW-PE (Upper & Lower)
- G : UHMW-PE/Leather Staggered (Upper & Lower)
- P : UHMW-PE/Teflon Staggered (Upper), UHMW-PE (Lower)
- R : Teflon/UHMW-PE Staggered (Upper), Teflon (Lower)

# Accessories

- Air F/R/L: C28241-810
- Airline Oil: 62274
- Air Motor Muffler: 91790
- Wet Sol: 66333-B
- Floor Mount: 65138
- Rams: Page 14

