

# Pump Performance

- Air Inlet Pressure Range . . . . . 30 - 120 PSI (2 - 8.3 bar)
- Fluid Pressure Range . . . . . 900 - 4500 PSI (61.2 - 306.1 bar)
- Max. Rec'd Cycles Per Minute . 60
- Displacement Per Cycle . . . . . 5.5 in<sup>3</sup> (90.1 cm<sup>3</sup>)
- Cycles Per Gallon (Liter) . . . . . 41.9 (11)
- Flow @ 60 Cycles / Minute . . . . 1.3 GPM (4.9 lpm)
- Noise Level @ 60 Psi . . . . . 81.8 db(A)

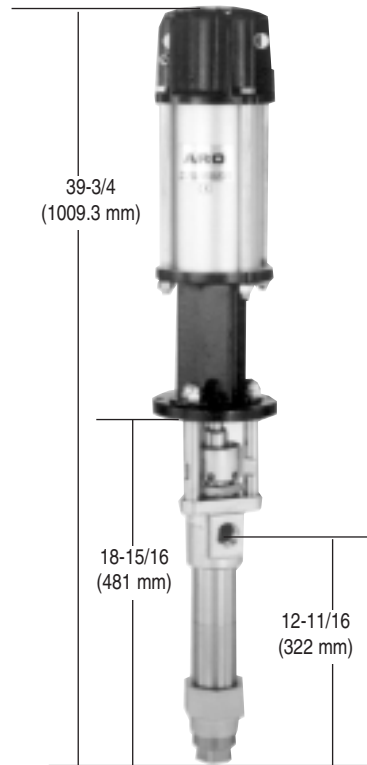

650485-X4X

# Pump Specifications

- Lower Pump Material . . . . . 316 Stainless Steel
- Plunger Material . . . . . See "Plunger Options" Below
- Cylinder Material . . . . . See "Plunger Options" Below
- Air Motor . . . . . 65465-B
- Motor Repair Kit . . . . . 61268
- Motor Diameter . . . . . 4-1/4"
- Stroke . . . . . 6"
- Air Inlet . . . . . 1/2" NPT(F)
- Exhaust Port . . . . . 1-1/4" NPT(F)
- Two-Ball Pump Model . . . . . 66302-X4X
- Lower Pump Repair Kit . . . . . 637307-X43
- Material Inlet . . . . . 1" NPT(F) 2" NPT(M)
- Material Outlet . . . . . 1" NPT(F)
- Weight . . . . . 42.9 lbs. (19.5 kgs.)

# Ordering

6 5 0 4 8 5 - X 4 X

### Packings

- 3 : Teflon
- C : UHMW-PE
- G : UHMW-PE/Leather Staggered
- P : UHMW-PE/Teflon Staggered (Upper), UHMW-PE (Lower)
- R : Teflon/UHMW-PE Staggered (Upper), Teflon (Lower)

### Plungers

- 3 : 17-4 S. S. Hard Chrome Plated
- B : 17-4 S.S. "Ultra" Coated

# Accessories

- Air F/R/L: C28241-810
- Airline Oil: 62274
- Air Motor Muffler: 91790
- Wet Sol: 66333-B
- Floor/Follower Adapter: 67136
- Floor Mount: 65138

