

Pump Performance

- Air Inlet Pressure Range 30 - 120 PSI (2 - 8.3 bar)
- Fluid Pressure Range 660 - 3300 PSI (44.8 - 224.4 bar)
- Max. Rec'd Cycles Per Minute . 60
- Displacement Per Cycle 7.5 in³ (122.9 cm³)
- Cycles Per Gallon (Liter) 30.8 (8.1)
- Flow @ 60 Cycles / Minute 1.9 GPM (7.2 lpm)
- Noise Level @ 60 Psi 81.8 db(A)



Pump Specifications

- Lower Pump Material 316 Stainless Steel
- Plunger Material See "Plunger Options" Below
- Cylinder Material See "Plunger Options" Below
- Air Motor 65465-B
- Motor Repair Kit 61268
- Motor Diameter 4-1/4"
- Stroke 6"
- Air Inlet 1/2" NPT(F)
- Exhaust Port 1-1/4" NPT(F)
- Two-Ball Pump Model 66301-X4X
- Lower Pump Repair Kit 637306-X43
- Material Inlet 1" NPT(F) 2" NPT(M)
- Material Outlet 1" NPT(F)
- Weight 42.9 lbs. (19.5 kgs.)

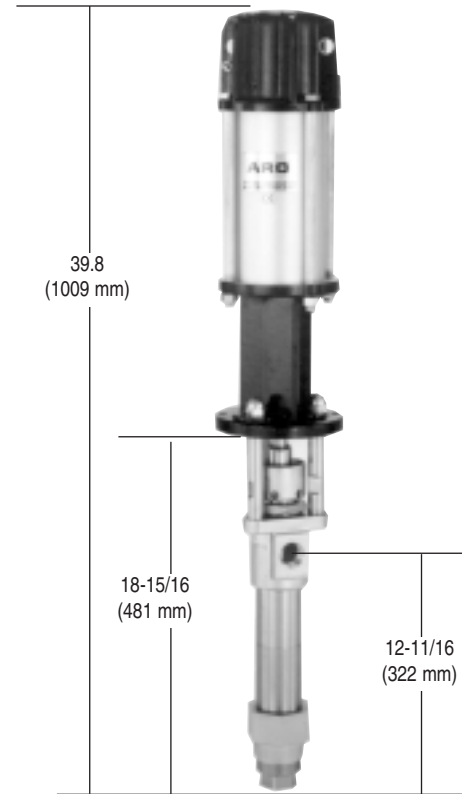

650484-X4X

Ordering

- 6 5 0 4 8 4 -X 4 X**
- Packings**
 - 3 : Teflon
 - C : UHMW-PE
 - G : UHMW-PE/Leather Staggered
 - P : UHMW-PE/Teflon Staggered (Upper), UHMW-PE (Lower)
 - R : Teflon/UHMW-PE Staggered (Upper), Teflon (Lower)
 - Plungers**
 - 3 : 17-4 S. S. Hard Chrome Plated
 - B : 17-4 S.S. "Ultra" Coated

Accessories

- Air F/R/L: C28241-810
- Airline Oil: 62274
- Air Motor Muffler: 91790
- Wet Sol: 66333-B
- Wall Mount: 66100
- Floor/Follower Adapter: 67136
- Floor Mount: 65138

