

Series EAU Electric Actuators

For Use With Ball Valves up to 2" Size



Features

- Plastic Housing
- Low Cost/High Quality
- On/Off Applications
- Auxiliary Limit Switch
- UL AND CSA-Listed Motor
- Nema 4/4X Housing
- Very Light Weight
- Permanent Lubrication
- 115 VAC Operation

Options

- Voltage Options: 12 VDC, 24 VDC, 12 VAC, 24 VAC, 220 VAC

Corrosion Resistant

Hayward EAU Series Electric Actuators come standard with an all-polypropylene housing for superior corrosion resistance. These NEMA 4 plastic housings can stand up to harsh environmental conditions and corrosive conditions, places where a metal actuator has to be painted or coated just to survive.

Best for On/Off Applications

These low cost, high quality electric actuators are the best choice for True Union and Three-Way Ball Valves up to 2" sizes where a manual override is not required and control options are not needed..

Extra Features - No Extra Cost

Low cost doesn't mean a stripped down, no frills actuator. Hayward EAU Series Electric Actuators come standard with a mechanical brake for precise control of the actuation cycle. Also standard is one auxiliary limit switch which permits control of a remote electrical device. Plus, a thermal overload circuit protects the UL-listed motor from burnout and overheating. All models include a wiring terminal strip.

Two Models Available

The EAU 29 actuator is designed for True Union Ball Valves and has a 90-degree, unidirectional rotation. The EAU 28 works with Three-Way Ball Valves and has a 180-degree unidirectional rotation. Both models have a 110 VAC motor with a 25% duty cycle.

Technical Information

Actuator Specifications

Housing:	Polypropylene Plastic	Aux Limit Switches:	1
Conduit Size:	1/2"	Enclosure:	NEMA 4/4X
Duty Cycle:	25%	Mechanical Break:	Standard
Motor:	110 VAC @ 2.8 Amp	Thermal Overload:	Standard
Cycle Times:	2.5 Seconds, 90 Degrees 5.0 Seconds, 180 Degrees	Weight:	6 lb/2.7 kg

Dimensions / Schematic

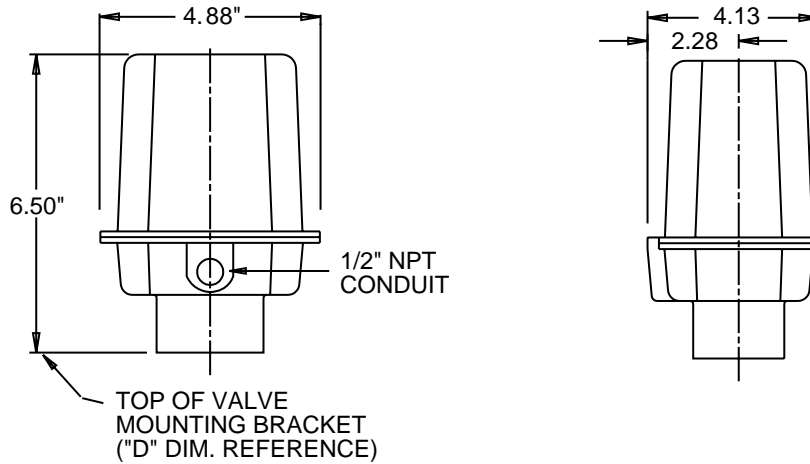

Torque Output	
150 in-lb	Start
180 in-lb	Stop

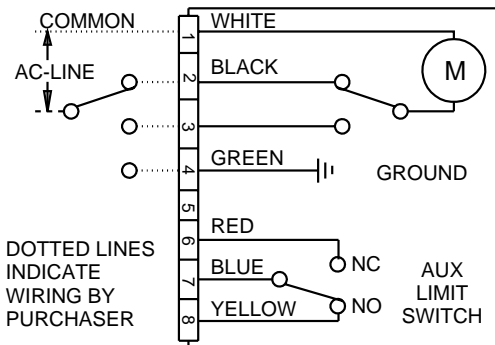

Selection Chart

Valve Size	True Union Ball Valve*	Three-Way Ball Valve*
1/2" to 2"	EAU 29	EAU 28

* Actuator size selections based on clean water at 70°F.



Hayward Industrial Products, Inc.

One Hayward Industrial Drive, Clemmons, NC 27012
 Tel: 1-888-429-4635 (1-888-HAYINDL) • Fax: 1-888-778-8410
 E-mail: industrial@haywardnet.com
 Web Site: <http://www.haywardindustrial.com>

Hayward Industrial Products (UK) Ltd.

Unit 2, Crowngate, Wyncolls Road
 Colchester, Essex C04 9HZ
 Tel: +44 (0) 1206 854454 • Fax: +44 (0) 1206 851240