

2/2-Way, G 1/2 - G 2, Flange connection



Advantages/Benefits

- ▶ Zero differential pressure
- ▶ Body material: brass, grey cast iron
- ▶ Fluid temperature up to 180 °C
- ▶ High reliability
- ▶ Erosion resistant

### Design/Function

Type 407 is a normally-closed servo-assisted on-off solenoid valve with a coupled armature / servo piston (circuit function A).

When de-energized, the spring acts on the armature to close the pilot channel in the piston.

When energized, the armature lifts to open the pilot channel to relieve the pressure. Even if there is no pressure differential, the armature lifts the coupled piston to open the valve.

### Applications

- Fluids at higher temperatures, e.g. hot air, steam
- Vacuum
- Autoclaves (vacuum side)
- Relief of steam systems
- All industrial areas

**bürkert**  
Easy Fluid Control Systems

# Solenoid Valve for steam and media at high temperatures up to 180 °C

## Type 407

### Technical Data

#### Circuit Function

A 2/2-way valve,  
normally closed,  
with 2-way pilot control

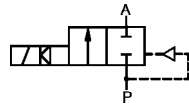

#### Body Material

Threaded: Body of brass, seat 1.4303  
Flanged: Body of grey cast iron, seat 1.4305  
Internal parts: Solenoid system 1.4105  
Servo piston of brass  
Cover: Brass (also for grey cast iron body)

#### Specifications

Orifice DN [mm]	Kv-Value		QNN-Value Air [l/min]	Pressure Range [bar]	Weight Thread [kg]	Flange [kg]
	Water [m³/h]					
13	3,7		4000	0-10	1,0	-
20	5,0		5400	0-10	1,4	-
25	10,0		10800	0-10	1,9	-
32	16		17200	0-10	3,2	-
40	16		17200	0-10	3,65	-
50	36		36800	0-10	7,8	12,8

The pressure range is also valid for technical vacuum. All pressures quoted are gauge pressures with respect to the prevailing atmospheric pressure.

#### Operating Data (Valve)

#### Seal Materials/Fluids Handled/Temp.- Range

PTFE Neutral fluids, e.g. hot water, steam  
0 to +180 °C

For more detailed information, please refer to resistance chart (Leaflet-No. 1896009).

Max. ambient temperature +55 °C

Max. viscosity 21 mm²/s

Response times DN opening

	[ms]	[ms]
13-25	0,1 - 0,2	0,3 - 0,5
32-50	0,2 - 1,2	1,0 - 3,0

Measured at outlet port A from switching on until pressure rise to 90 % / pressure drops to 10 % at a working pressure of 1.5 bar.

Port connection G 1/2, 3/4, 1, 1 1/4, 1 1/2, 2  
Flanged

#### Operating Data (Actuator)

Operating voltages 240, 230, 110, 24 V/50  
110 V/60 Hz  
24 V/=  
110, 220, 240 V/UC  
(universal current)

Voltage tolerance ±10 %

Power consumption AC 100 VA (inrush)  
35 VA/16 W (hold)  
DC 28 W at DN 50

Duty cycle 100 % continuously rated

Cycling rate 10-60 c.p.m.

Rating with IP 65 cable plug

#### Installation / Accessories

Installation as required, but preferably with solenoid system

Electrical connection upright

- cable plug for 6-7 mm ø cable (supplied as standard)
- cable plug 1051-2007 with integrated single-phase bridge (standard for universal current versions)

# Solenoid Valve for steam and media at high temperatures up to 180 °C

## Type 407

Dimensions in mm

### Ported Version

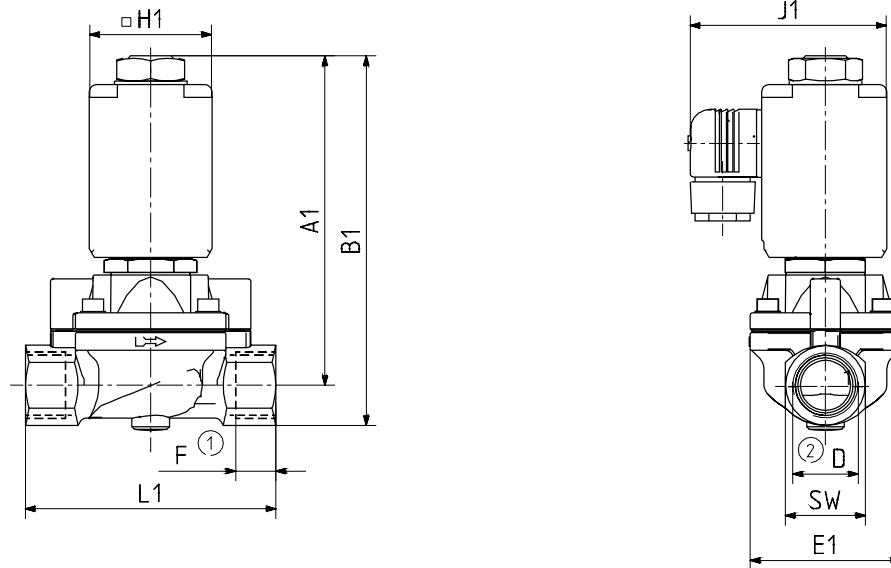

### Flanged Version

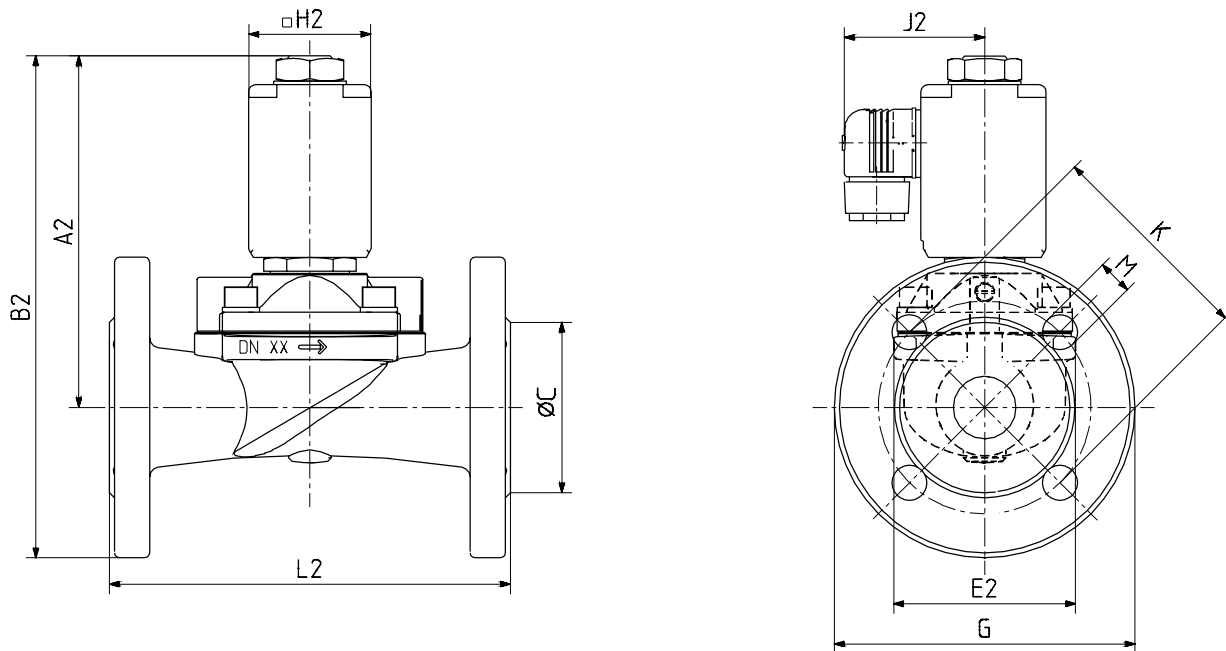

Orifice [mm]	Ported Version									Flanged Version										
	A1	B1	D	F	E1	L1	SW	J1	H1	A2	B2	ØC	E2	G	L2	M	K	J2	H2	
13	113	127	G 1/2	14	40	65	27	73	40											
20	131	147	G 3/4	16	60	100	32	80,5	49											
25	136,5	157	G 1	18	70	115	41	80,5	49											
32	161	186	G 1 1/4	20	85	126	50	80,5	49											
40	165	195	G 1 1/2	22	85	126	60	80,5	49											
50	225	260	G 2	24	115	164	70	104,5	72	225	307,5	102	115	165	230	18	125	104,5	72	

# Solenoid Valve for steam and media at high temperatures up to 180 °C

## Type 407

### Ordering Chart (Other Versions on Request)

Circuit Function	Orifice DN [mm]	Flow Rate		Port Connection	Pressure Range [bar]	Body Material	Seal Material	Weight [kg]	Voltage/ Frequency [V/Hz]	Order-No.
		Water Kv-Value [m³/h]	Air Q/Nn [l/min]							
A	13,0	3,7	4000	G 1/2	0-10	Brass	PTFE	1,0	024/50	021 598 J
									110/50	024 411 H
									110/60	077 089 X
									230/50	615 637 Y
									240/50	021 791 K
	20,0	5,0	5400	G 3/4	0-10	Brass	PTFE	1,4	024/50	022 032 E
									110/50	021 792 L
									110/60	078 549 R
									230/50	615 157 X
									240/50	021 880 R
25,0	10,0	10800	G 1	0-10	Brass	PTFE	1,9	024/50	021 620 T	
								110/50	024 412 A	
								110/60	077 625 U	
								230/50	615 638 H	
								240/50	021 793 M	
32,0	16,0	17200	G 1	0-10	Brass	PTFE	3,2	024/50	085 385 M	
								110/50	085 386 N	
								230/50	064 919 W	
								240/50	085 387 P	
40,0	16,0	17200	G 1	0-10	Brass	PTFE	3,65	024/50	085 392 L	
								110/50	085 393 M	
								230/50	085 394 N	
								240/50	085 395 P	
50,0	36,0	36800	Flanged	0-10	Cast iron	PTFE	12,8	220/UC <sup>1)</sup>	085 406 K	
			G 2	0-10	Brass	PTFE	7,8	024/=	085 400 Z	
									110/UC <sup>1)</sup>	085 401 N
									220/UC <sup>1)</sup>	085 402 P
									240/UC <sup>1)</sup>	085 403 Q

<sup>1)</sup> UC universal current, cable plug with integrated single-phase rectifier bridge.